

596

THERMACORE[®] DOOR SYSTEMS



EXTRA HEAVY-DUTY INSULATED STEEL SECTIONAL DOORS



**SOUND SUPPRESSION CAPABILITIES.
EXCEPTIONAL THERMAL EFFICIENCY.**



INDUSTRY LEADING
COMMERCIAL & INDUSTRIAL SOLUTIONS



Standard features at a glance

Thermal efficiency

R-value*	17.40 (3.06 K m ² /W)
U-value	.057 (.327 W/K m ²)
Thermal break	PVC
Air infiltration	at 15 mph (24 kmph): .08 cfm/ft ² (1.46 m ³ /hr/m ²)

Construction

Panel thickness	2" (51 mm)
Max height**	24'1" (7341 mm)
Max width**	36'2" (11024 mm)
Exterior steel	20-gauge galvanized
Exterior surface	Flush, textured
Standard springs	10,000 cycle
Sound transmission rating	Class 26

Color options

Interior colors	White
Exterior colors	White, Gray, Tan, Industrial Brown

Limited warranty

10-year delamination
1-year door
3-year/20,000 cycle door and operator system (material and workmanship)

Options

- Thermal glazing
- Aluminum sash section available to 24'2" (7366 mm) wide
- Four section pass door
- High-usage components
- Wind load options
- Electric operator
- Chain hoist
- Posi-Tension™ drums
- Safety bottom fixtures
- Bottom-sensing edge
- Flexible jamb, header seal
- Exhaust ports

* R-value is a measure of thermal efficiency. The higher the R-value the greater the insulating properties of the door. Overhead Door Corporation uses a calculated door section R-value for our insulated doors.

** Maximum door size is dependent on weight. Doors are not available to the maximum height at the maximum width.

Image above: Gray finish, Double Thermal Acrylic

Cover image: White finish, Double Thermal Acrylic



Superior sound suppression

The Thermacore® Model 596 is ideal for extra heavy-duty applications where both thermal efficiency and sound suppression are desirable.

It incorporates the Thermacore® steel-polyurethane-steel panel construction, which provides a thermal barrier to withstand harsh climates and demanding environmental requirements. The result is a solid, well-built door that keeps both the weather and unwanted sound at bay.



Installation and service: Overhead Door Company of Glens Falls™

Panel options



Flush panel

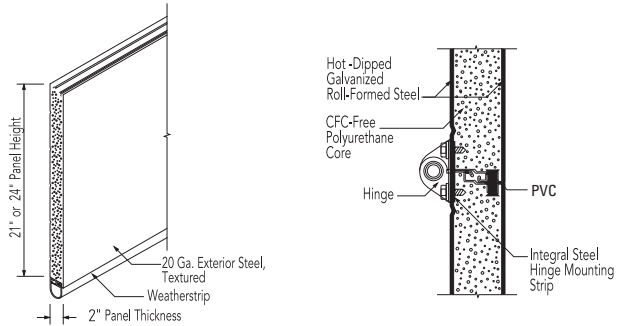

Color options



White

Industrial Brown

Gray

Tan

Actual colors may vary from brochure due to fluctuations in the printing process. Always request a color sample from your Overhead Door™ Distributor for accurate color matching.

Glazing options



Double Thermal Acrylic (25" w by 12" h)



Aluminum Sash Section* with DSB glazing

*Standard color White



Insulated DSB (24" w by 7" h)



Clear Long** (44" w by 15" h)

**Not available on doors wider than 20'2"



Installation and Service: Overhead Door Company of Twin Falls™.



Tools to help you
get the job done.

Architect's Corner

A resource for architects, containing comprehensive technical and resource materials to support your project, including drawings and specifications for commercial doors.

The original, innovative choice for unequalled quality and service.

Overhead Door Corporation pioneered the upward-acting door industry, inventing the first upward-acting door in 1921 and the first electric door operator in 1926. Today, we continue to be the industry leader through the strength of our product innovation, superior craftsmanship and outstanding customer support, underscoring a legacy of quality, expertise and integrity. That's why design and construction professionals specify Overhead Door™ products more often than any other brand. Our family of over 400 Overhead Door™ Distributors across the U.S. and Canada not only share our name and logo, but also our commitment to excellence.



INDUSTRY LEADING
COMMERCIAL & INDUSTRIAL SOLUTIONS

📍 Fray Pedro de Gante 85, Cimatario, Santiago de Querétaro, Querétaro, México CP 76030

📞 (442) 727-0441

✉️ contacto@klh.com.mx

klh de México
www.klh.com.mx